

Model 528 -CA

For most tubs 14" - 16" high

Model 538 -CA

For most tubs up to 24" high

Sturdy 1.5" 17g or 20g Tubular Brass Slip-Joint Assembly

SPECIFICATIONS

FEATURES:

- Sturdy all-brass construction
- No plastic parts
- Designed for heavy-duty use in hotels, motels, and rental property

APPROVALS:

- Manufactured in compliance with ASME A112.18.2-2005/CSA B125.2-2005.

OPERATION:

- 7XUQ RYHUÀRZ SODWH FORFNZLVH W FRXQWHU FORFNZLVH WR RSHQ GUDL

THREAD SIZE (Strainer Body and Drain Elbow):

- 1 1/2" – 1 1/2" NPSM (Coarse Thread)
- 1.865" Major Diameter (outside thread diameter)
- 11.5 threads per inch

PIPING: 17-gauge or 20-gauge brass

OPTIONS:

- Brass Ferrules (add code "F" to part number)
- 1HZ <RUN /D\ 'RZQ 7HH DGG FRGH 3 1 number)
- Slip-'N-Solder (no compression slip joints; add code "U")
- Special lengths available:
 - 2YHUÀRZ H[WHQVLR @engD]GG FRGH 3 (; example: EX6
 - 'UDLQ H[WHQVLR @engD]G&anFpR.G4 3'
- For 17-gauge Brass add feature -17G

FINISHES:

Tub Closure:	Cable Stopper
BO-Bone	•
% 1 % U X V K H G 1 L F N H O	•
BS - Biscuit	•
BZ - Oil-Rubbed Bronze	•
CB - Chrome Brushed	•
CP - Chrome Plated	•
1 3 1 L F N H O 3 R O L V K H G	•
PB - Polished Brass	•
WH - White	•
: , : U R X J K W , U R Q O D W W H % O D F N	

Both models available in 17-gauge brass with an additional charge.

To order 17-gauge:

ADD "-17G" to part number.

Example: 538-CA-BRS-CP-17G

See price list for complete item numbers and available options.

When ordering, please specify complete item number and any applicable option codes.

WATCO



For More Information Contact:
 WATCO Manufacturing Company
 1220 South Powell Road
 Independence, MO 64057-2724
 Ph. 816-796-3900 • FAX 816-796-0875
www.watcomfg.com

528-CA/538-CA Series Parts List

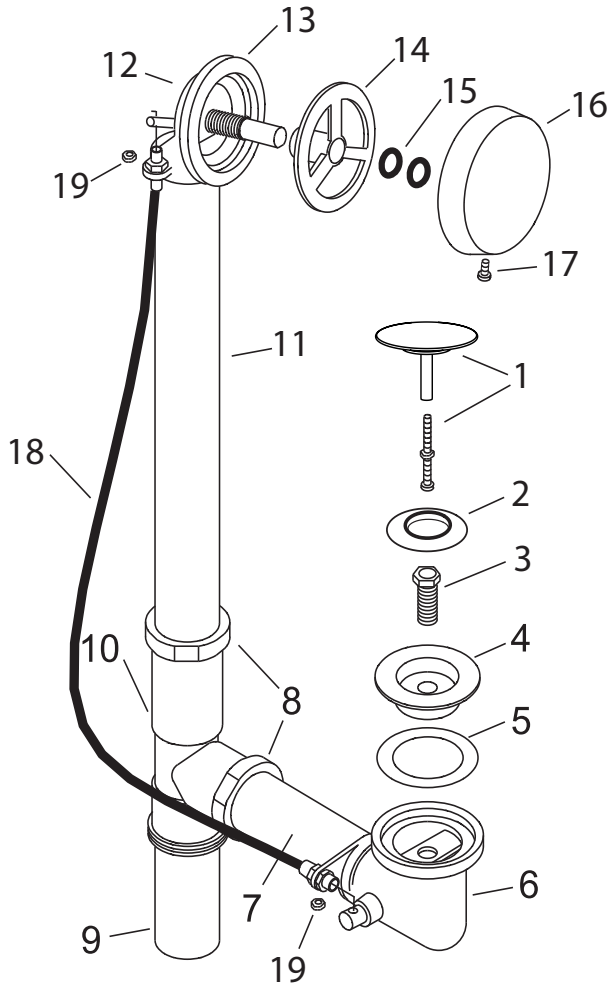

Item	Part #	Description
1	20065 *	Cable Full-Cover Stopper assembled with
	(20110)	adjusting screw and
	(20120)	adjusting nut
2	11507	Cable Faceplate
3	20040	Cable Overflow Elbow Retainer Nut
4	20080 *	Cable Strainer Body
5	20130	Cable Drain Ell Washer
6	20085	Cable Drain Elbow Assembly
7	20GA-4.75	528: DE Pipe, 20g Brass, 1.5" x 4.75"
	17GA-4.75	528: DE Pipe, 17g Brass, 1.5" x 4.75"
	20GA-6.75	538: DE Pipe, 20g Brass, 1.5" x 6.75"
	17GA-6.75	538: DE Pipe, 17g Brass, 1.5" x 6.75"
8	41580	Brass Slip Nut and
	11583	Slip Joint Polywasher, 1.5"
9	20GA-3.5	Tail Piece, 20g Brass, 1.5" x 3.5"
	17GA-3.5	Tail Piece, 17g Brass, 1.5" x 3.5"
10	44001	Tee, Brass
11	20GA-15.62	528: OF Pipe, 20g Brass, 1.5" x 15.625"
	17GA-15.62	528: OF Pipe, 17g Brass, 1.5" x 15.625"
	20GA-23.62	538: OF Pipe, 20g Brass, 1.5" x 23.625"
	17GA-23.62	538: OF Pipe, 17g Brass, 1.5" x 23.625"
12	20035	Cable OF Ell Assembly with 20041 turning pin
13	20100	Cable Overflow Ell Washer
14	20020 *	Overflow Mount with prongs
	20021 *	Cable Mounting Bracket without prongs
15	11134	Cable O-Ring: AS 568A-204 (two Required)
16	20030 *	Cable Overflow Plate
	20140	Cable Overflow Plate Locking Screw
18	20156	528: Cable Sleeve Ass'y., brass threads, 22.125"
	20160	538: Cable Sleeve Ass'y., brass threads, 31.0"
19	20122	Nut for Cable Wire

Roughing-In Dimensions:

Cable Drains

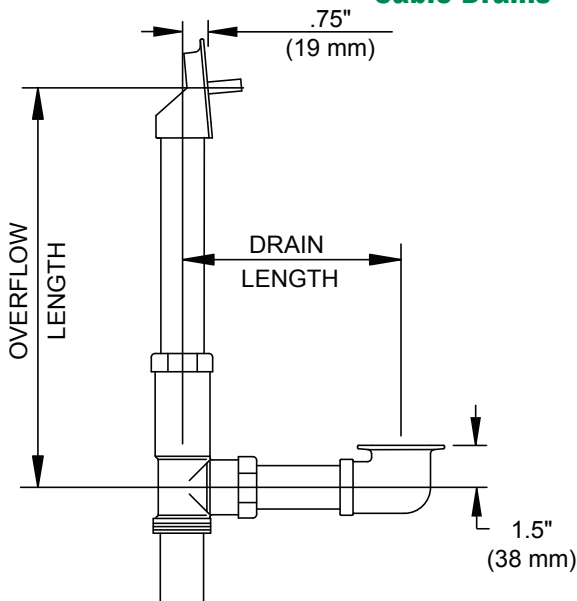

Model 528-CA:

Overflow length plus drain length cannot exceed 28 inches.

STANDARD: Overflow Length = 20 inches
 Drain Length = 8 inches

Model 538-CA:

Overflow length plus drain length cannot exceed 38 inches.

STANDARD: Overflow Length = 28 inches
 Drain Length = 10 inches

Please Note: If lengths needed are not within the standards above, lengths needed must be clearly noted on order.