

Tubular Brass

Model 528-CA

For most tubs 14" - 16" high

Model 538-CA

For most tubs up to 24" high

Sturdy 1.5" 20g Tubular Brass Slip-Joint Assembly

SPECIFICATIONS

FEATURES:

- Sturdy all-brass construction
- No plastic parts
- Designed for heavy-duty use in hotels, motels, and rental property

APPROVALS:

- Manufactured in compliance with ASME A112.18.2-2005/CSA B125.2-2005.

OPERATION:

- Turn overflow plate clockwise to close drain and counter-clockwise to open drain.

THREAD SIZE (Strainer Body and Drain Elbow):

- 1 $\frac{1}{2}$ " - 11 $\frac{1}{2}$ " NPSM (Coarse Thread)
- 1.865" Major Diameter (outside thread diameter)
- 11.5 threads per inch

PIPING: 20-gauge brass

OPTIONS:

- Brass Ferrules (add code "F" to part number)
- New York Lay-Down Tee (add code "NY" to part number)
- Slip-'N-Solder (no compression slip joints; add code "U")
- Special lengths available:
 - Overflow extension (add code "EXlength")
example: EX6
 - Drain extension (add code "Dlength") example: D4

FINISHES:

- CP - Chrome Plated
- BN - Brushed Nickel
- BO - Bone
- BS - Biscuit
- BZ - Oil-Rubbed Bronze
- CB - Chrome Brushed
- NP - Nickel Polished
- PB - Polished Brass
- WH - White
- WI - Wrought Iron

See price list for complete item numbers and available options.

When ordering, please specify complete item number and any applicable option codes.



For More Information Contact:
WATCO Manufacturing Company
1220 South Powell Road
Independence, MO 64057-2724
Ph. 816-796-3900 • FAX 816-796-0875
www.watcomfg.com

528-CA/538-CA Series Parts List

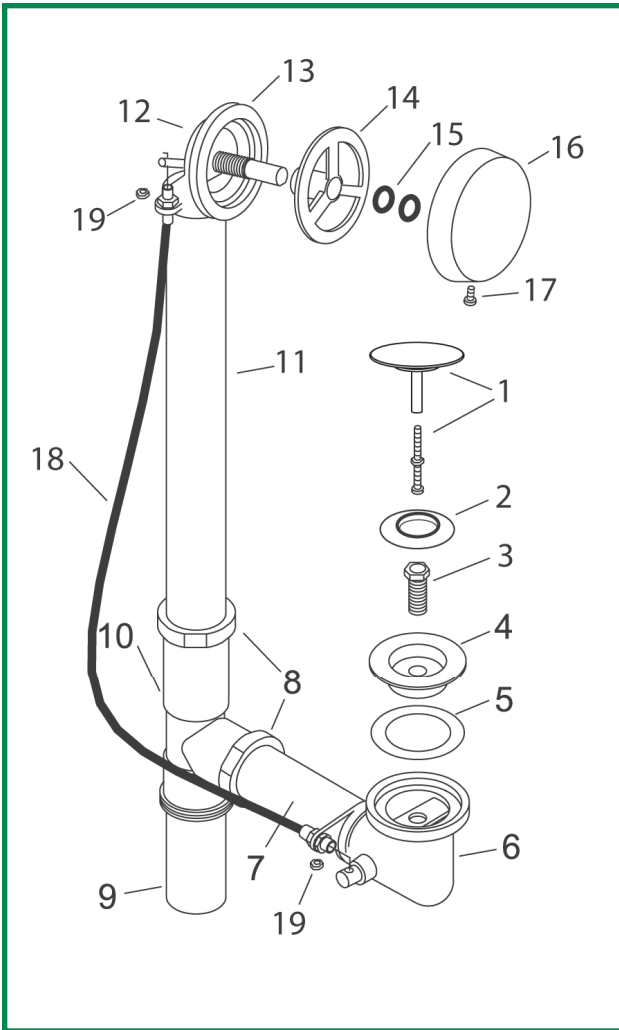

Item	Part #	Description	
1.	20065__*	Cable Full-Cover Stopper assembled with (20110) adjusting screw and (20120) adjusting nut	
2.	11507	PUSH PULL® Seal, 1 ¹ / ₁₆ " dia.	
3.	20040.....	Cable Drain EII Locking Pin	
4.	20080__*	Cable Strainer Body	
5.	20130	Cable Drain EII Washer	
6.	20085.....	Cable Drain Elbow Assembly	
7.	#528: 20GA-4.75	DE Pipe, 20g Brass, 1.5" x 4.75"	
	#538: 20GA-6.75	DE Pipe, 20g Brass, 1.5" x 6.75"	
8.	41580	Brass Slip Nut and 11583	Slip Joint Polywasher, 1.5"
9.	20GA-3.5 ..	Tail Piece, 20g Brass, 1.5" x 3.5"	
10.	44001.....	Tee, Brass	
11.	#528: 20GA-15.62	OF Pipe, 20g Brass, 1.5" x 15.625"	
	#538: 20GA-23.62	OF Pipe, 20g Brass, 1.5" x 23.625"	
12.	20035.....	Cable OF EII Assembly with 20041 turning pin	
13.	20100	Cable Overflow EII Washer	
14.	20020__*	Cable Overflow Mounting Bracket	
15.	11134.....	Cable O-Ring: AS 568A-204 (two provided)	
16.	20030__*	Cable Overflow Plate	
17.	20140	Cable Overflow Plate Locking Screw	
18.	#528: 20156 ...	Cable Sleeve Ass'y., brass threads, 22.125"	
	#538: 20160.....	Cable Sleeve Ass'y., brass threads, 31.0"	
19.	20122	Nut for Cable Wire	

*Please indicate desired finish.

Roughing-In Dimensions:

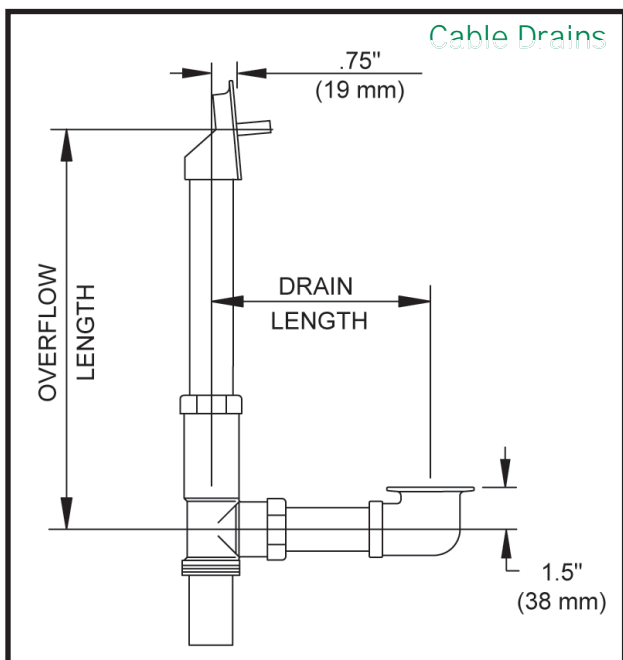

Model 528-CA:

Overflow length plus drain length cannot exceed 28 inches.

STANDARD: Overflow Length = 20 inches
 Drain Length = 8 inches

Model 538-CA:

Overflow length plus drain length cannot exceed 38 inches.

STANDARD: Overflow Length = 28 inches
 Drain Length = 10 inches

Please Note: If lengths needed are not within the standards above, lengths needed must be clearly noted on order.